

Meal Distribution System
2 Tier Service trolley with 1 handle
600x800mm

ITEM # _____

MODEL # _____

NAME # _____

SIS # _____

AIA # _____

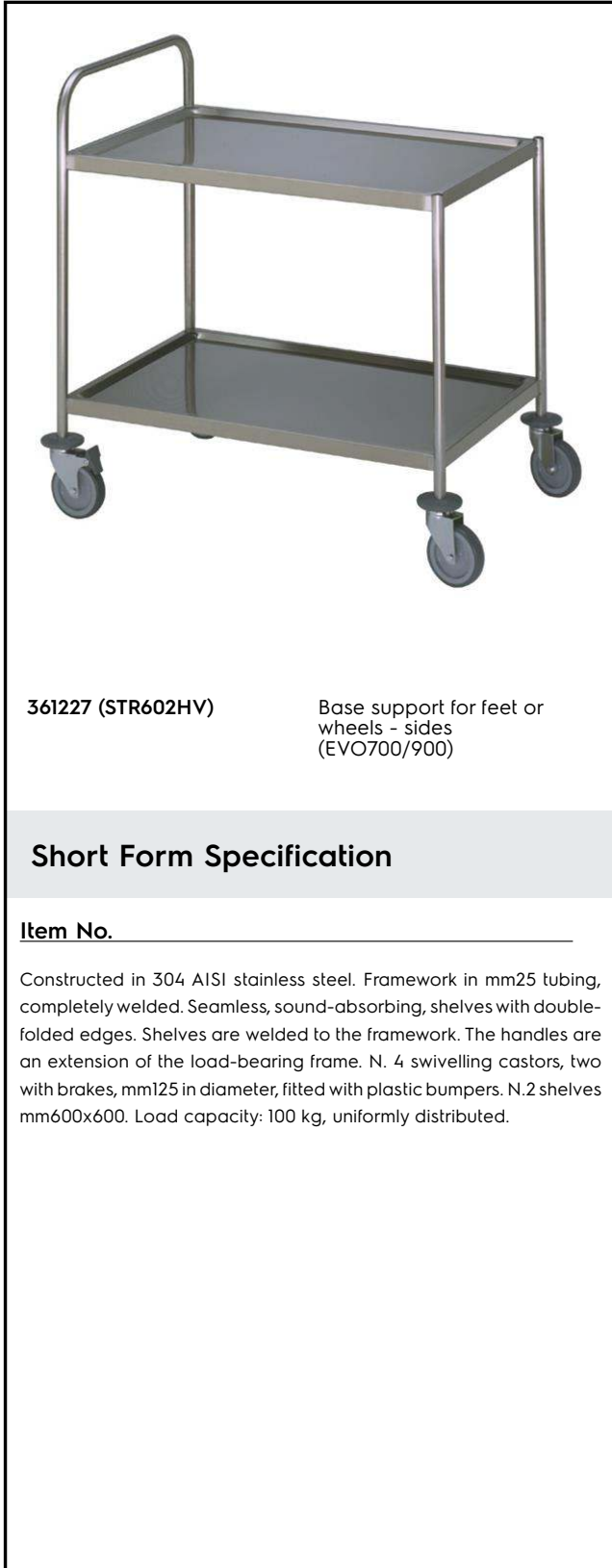

361227 (STR602HV)

Base support for feet or
wheels - sides
(EVO700/900)

Short Form Specification

Item No. _____

Constructed in 304 AISI stainless steel. Framework in mm25 tubing, completely welded. Seamless, sound-absorbing, shelves with double-folded edges. Shelves are welded to the framework. The handles are an extension of the load-bearing frame. N. 4 swivelling castors, two with brakes, mm125 in diameter, fitted with plastic bumpers. N.2 shelves mm600x600. Load capacity: 100 kg, uniformly distributed.

Main Features

- Service trolley with a loading capacity of 100 kg, evenly distributed.
- Seamless sound-absorbing shelves with double-folded edges welded to the framework.
- Shelf edges height prevents transported goods from falling.
- Strong ergonomic handle, extended from load-bearing frame.
- Equipped with 4 rubber bumpers and 4 swivelling wheels, 2 of which with breaks.

Construction

- Constructed in Stainless steel with Scotch Brite finish to meet the highest hygiene standards.

APPROVAL: _____

Front

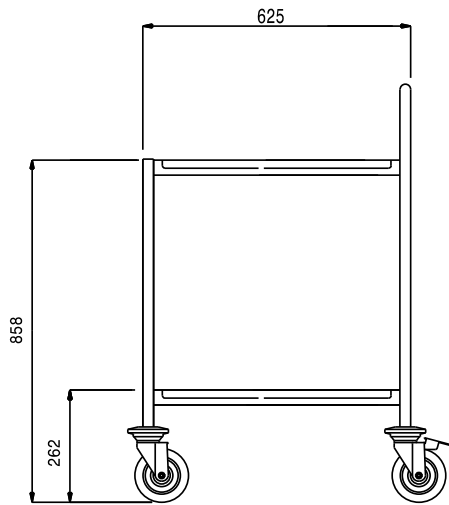

Side

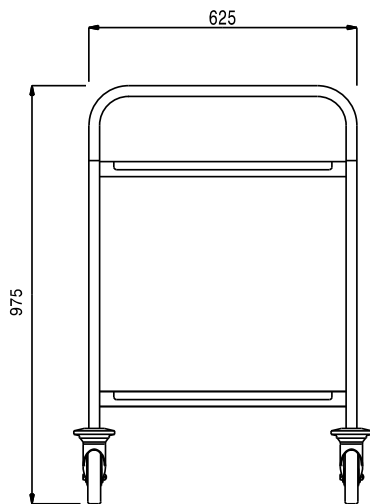

Top

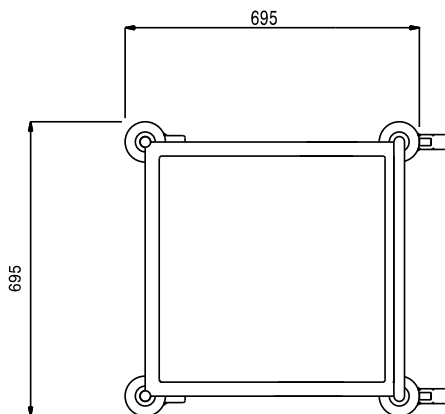

Key Information:

External dimensions, Width:	
361227 (STR602HV)	695 mm
External dimensions, Depth:	695 mm
External dimensions, Height:	975 mm
Net weight:	18 kg